

DC Microgrid RE/SOURCED Project

Leiedal Battery Storage Project on Transfo Site Zwevegem Belgium

Ben Hayen

&

Marc Van Goidsenhoven

CE+T Group

Sales Manager Energrid Belgium





BEN HAYEN

CEO CE+T GROUP



**MARC VAN
GOIDSENHOVEN**
SALES MANAGER

Re/Sourced Project

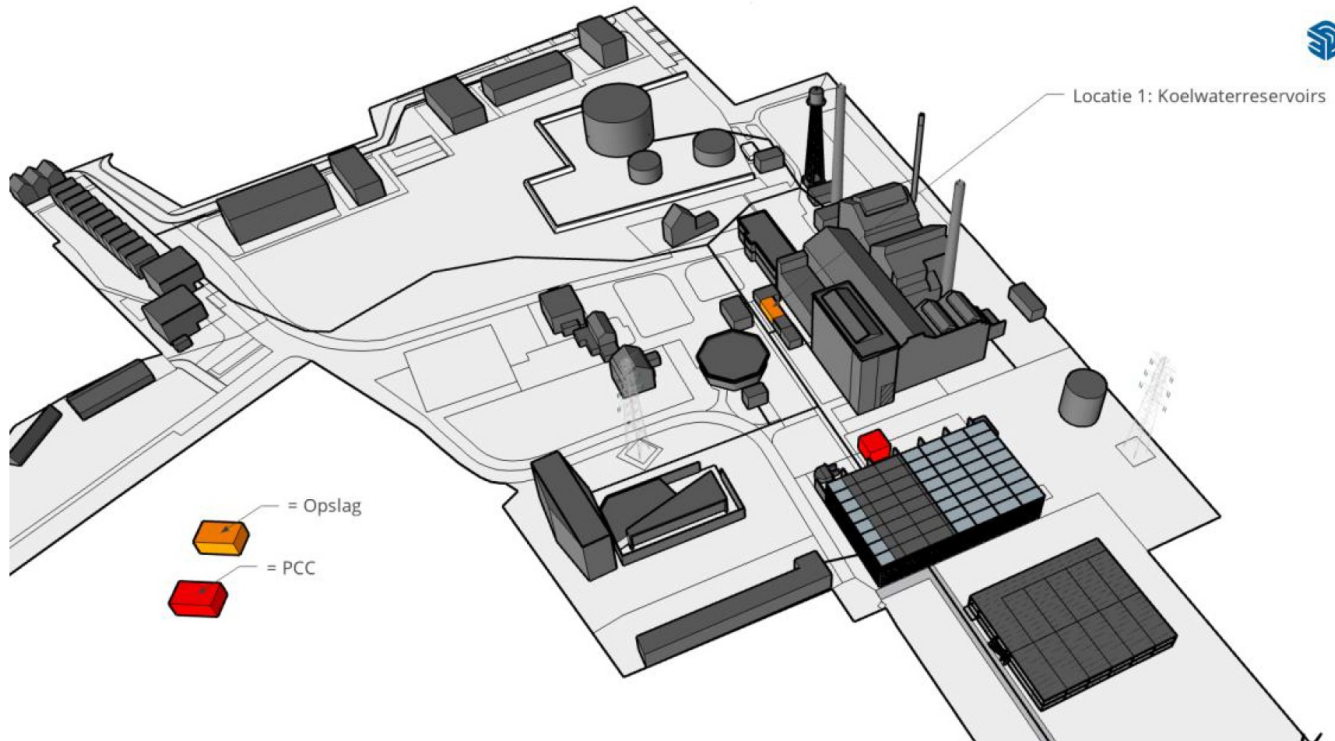

*Reconversion of old
DSO Power plant*

1 outdoor events



2 escape room



3 indoor events



4 diving tank



5 adventures sports



6 climbing hall



7 camping ground





Resourced Project Zwevegem Phase

DC Backbone 700VDC

- 160kW PCS / 307,8 kWh recycled battery
- Inview X controller
- Limited EMS functionality
 - Self-consumption optimization
 - Peak shaving
 - Energy arbitrage

PV Solar

- 320KWp PV panels
- 240KW Stabiliti + 30 KW
- Inview X controller

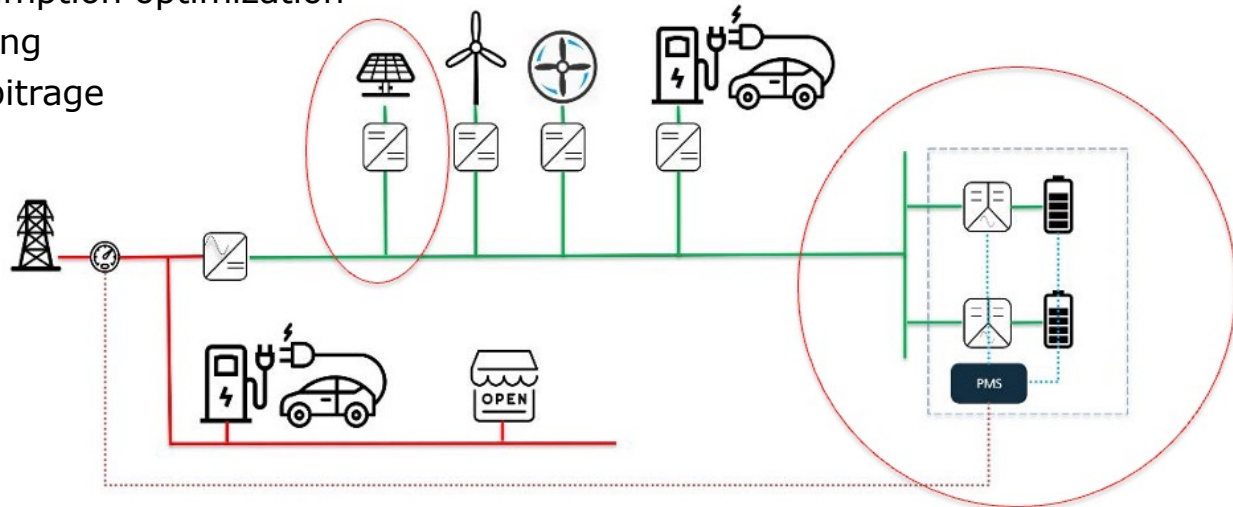

CE+T Converter Stability

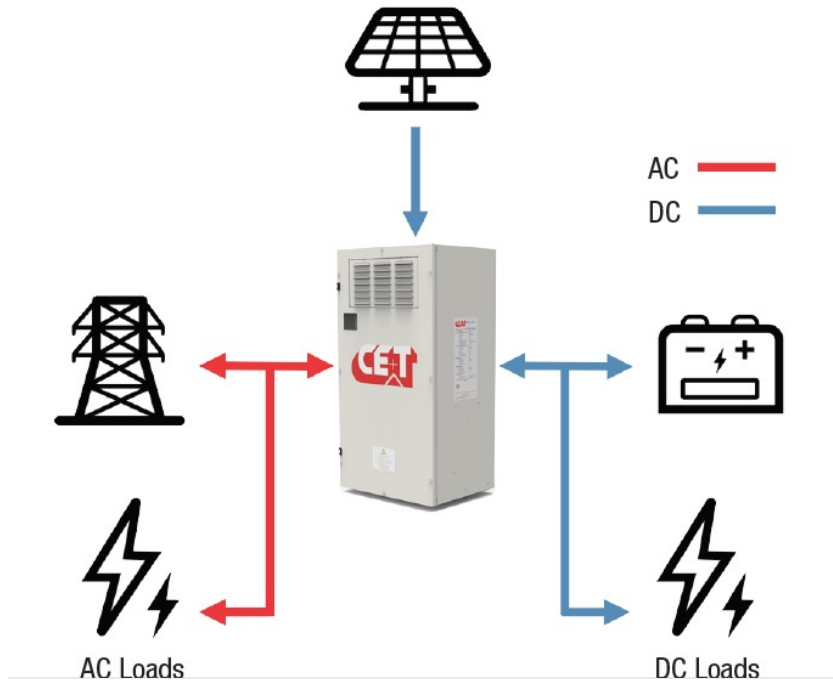

DC backbone

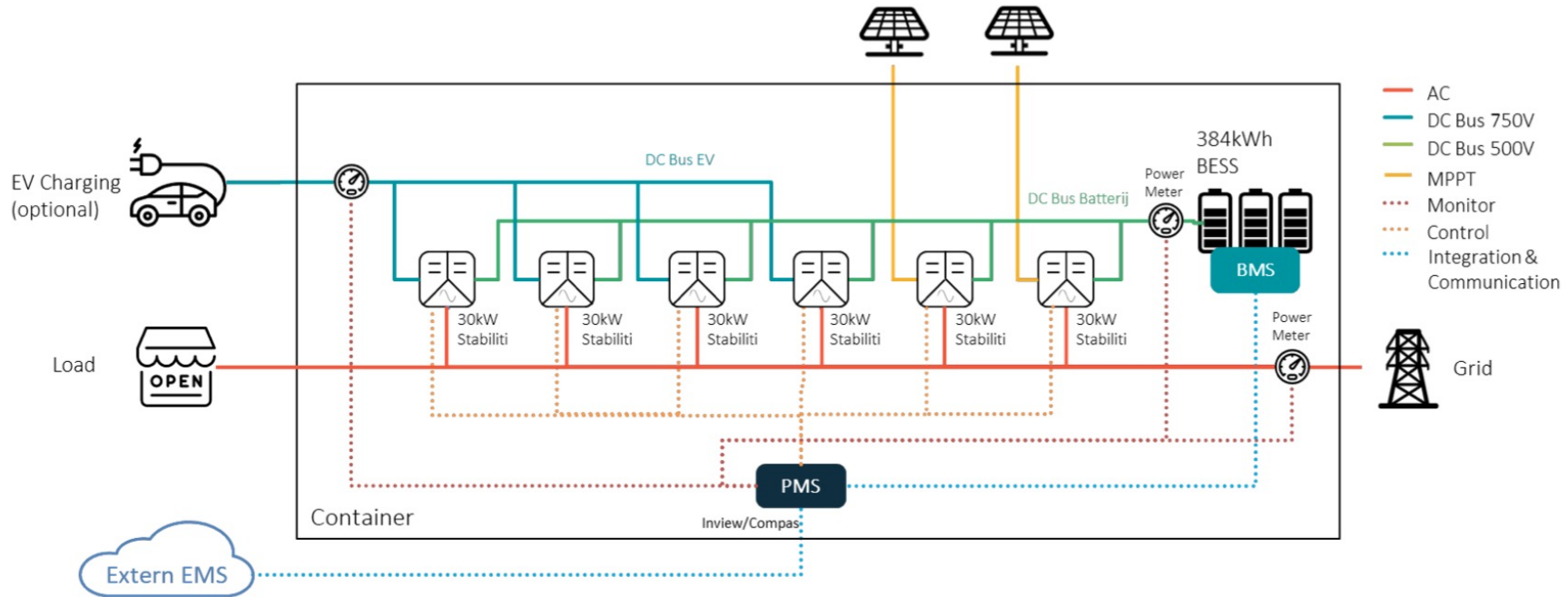

Detailed Schematic Phase HVDC Backbone and Storage

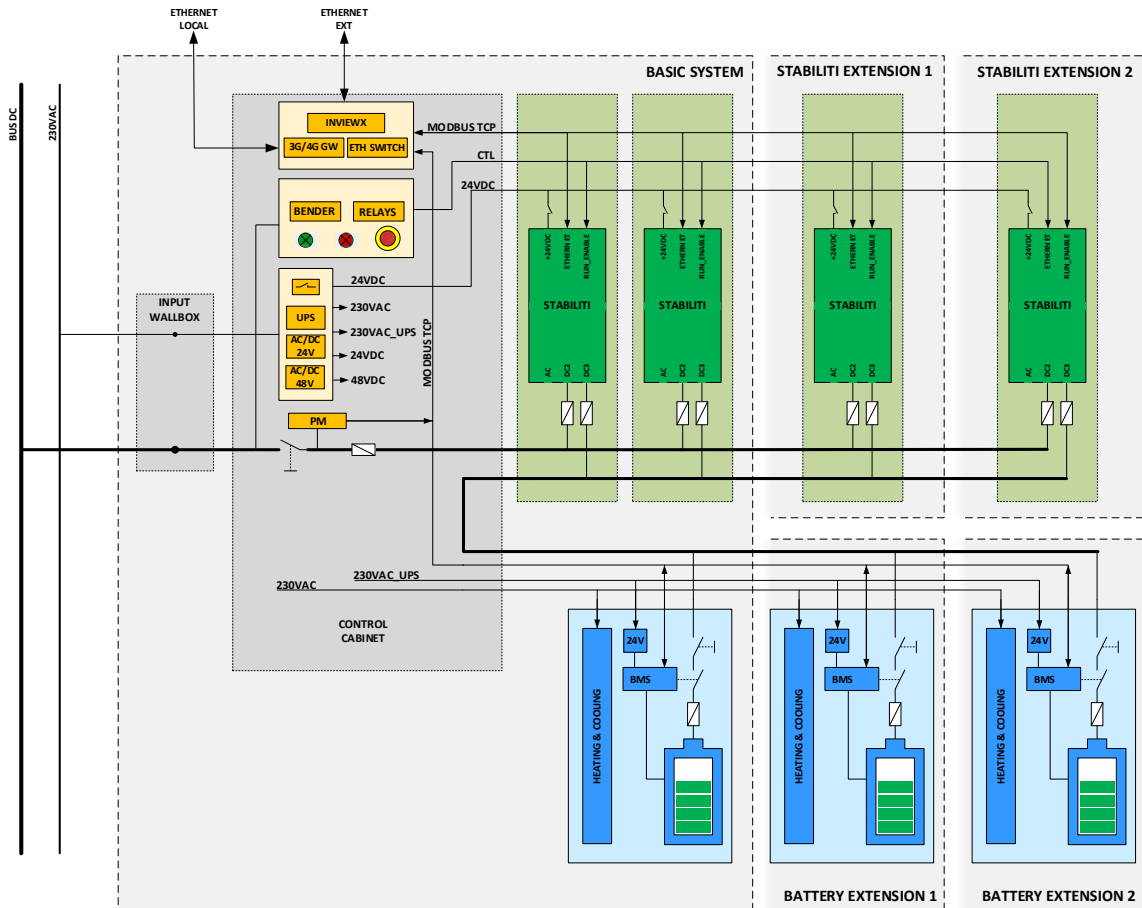

- DC-DC converter
 - Stabiliti 30KW
- Batteries, BMS
 - In climatized cabinets
- Inview X controller
 - With EMS funct.
- Connectivity & Protections
 - Contractors
 - Bender
 - UPS
 - 24V & 48V

Services Phase HVDC Backbone and Storage

- Engineering : detailed design, Electrical and mechanical as-built plans
- Training : 2 days for 8 persons in training center in Wandre.
- Installations
- Acceptance and Certification
- Functionial SAT (Site Acceptance Test)
- Comissioning
- 24/7 monitoring of the installation. Interpretation of the event in 4h, Intervention in 8h, average
- Inview Mesh monitoring online access to the system, various dashboards, realtime measurements
- Yearly planned preventive maintenance of the systems.
- One not planned intervention on call / other interventions at daily tarif

Phase Solar (EV charging optional)

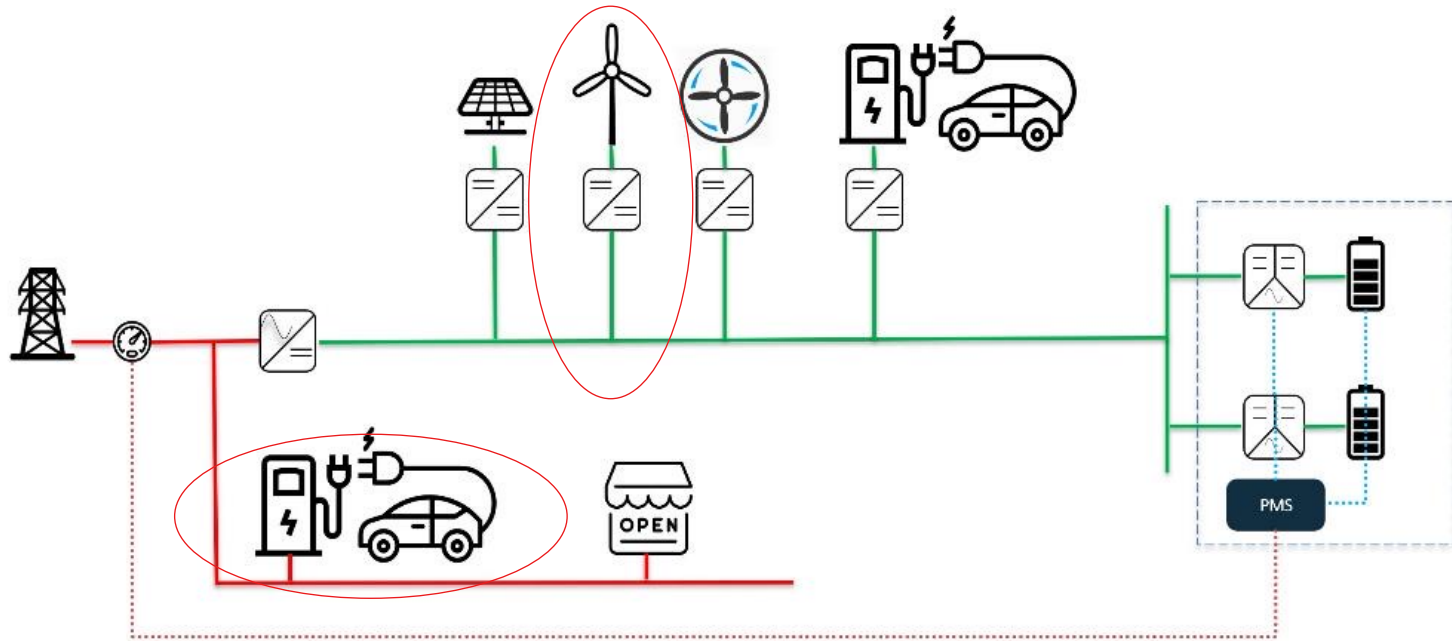

Phase Solar "Car park"

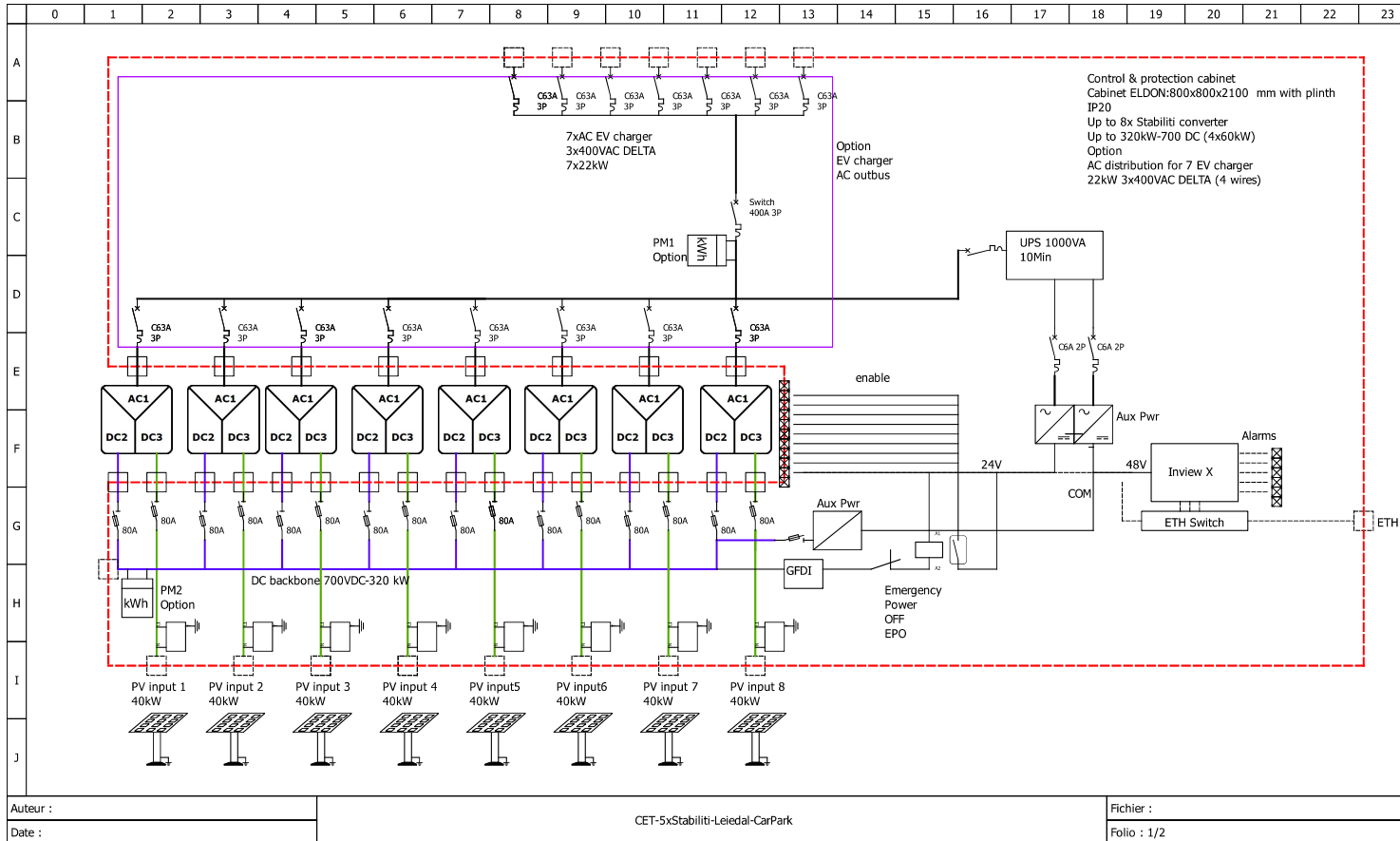

Phase Solar "Klimzaal"

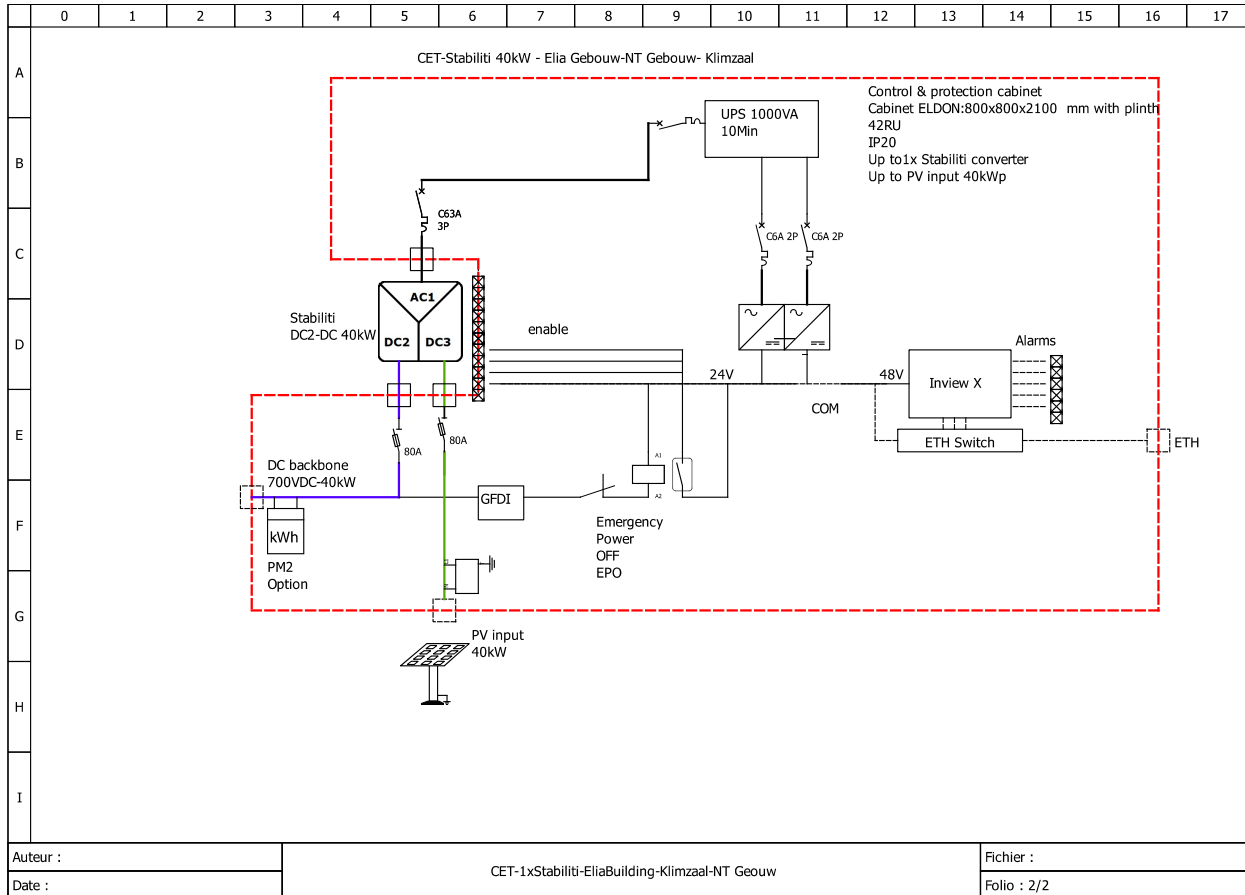

Phase AC/DC Converter Grid Connection

- AC/DC Converter
 - 2x 250KVA total of 20 Stabiliti
 - Inview X Controller

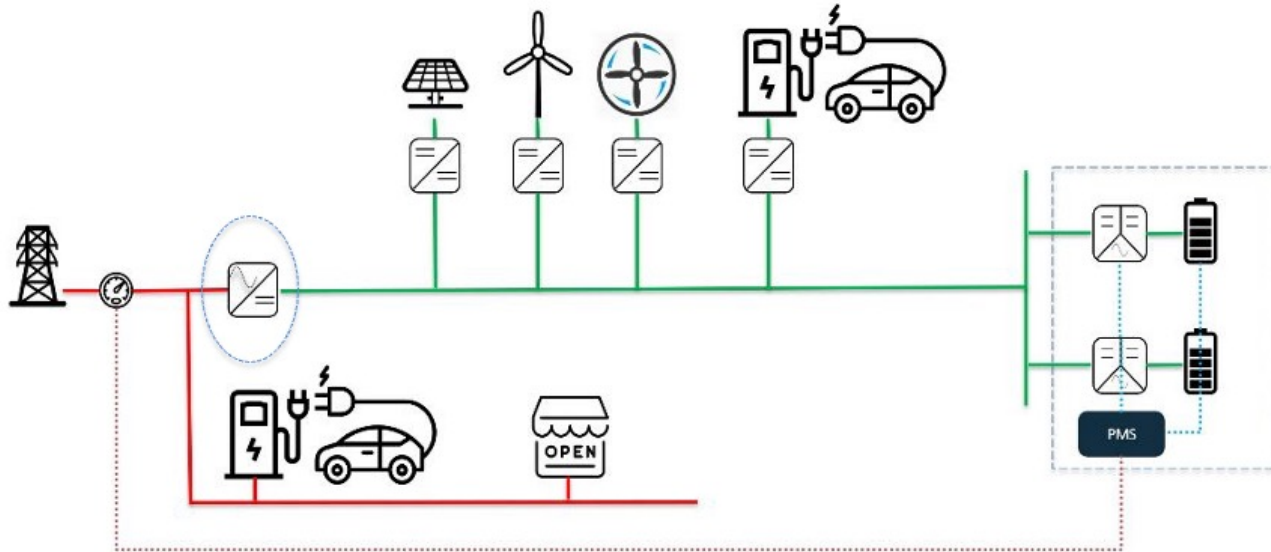

Phase AC/DC Converter Grid Connection (2x)

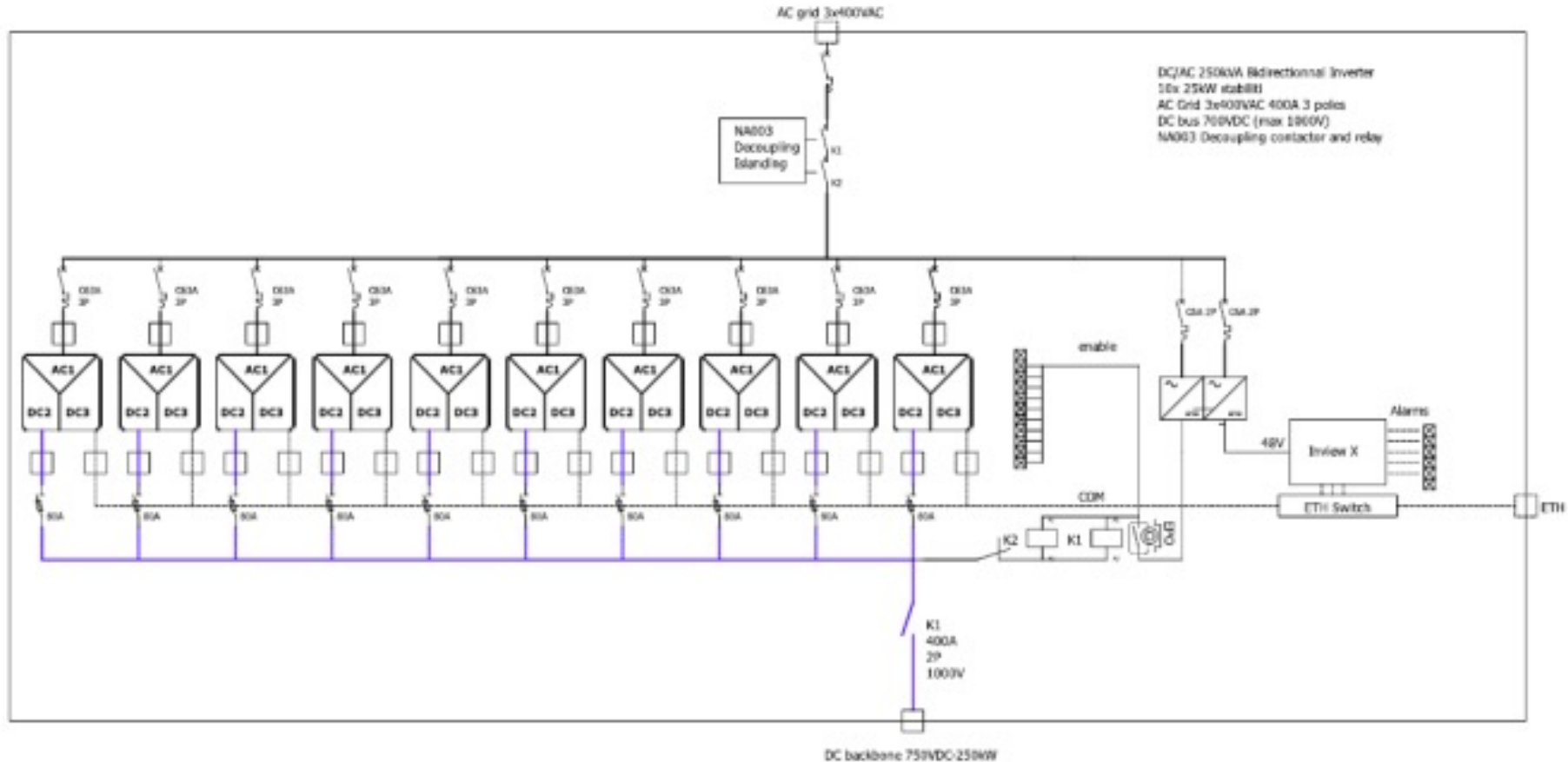

Phase DC/DC lab system

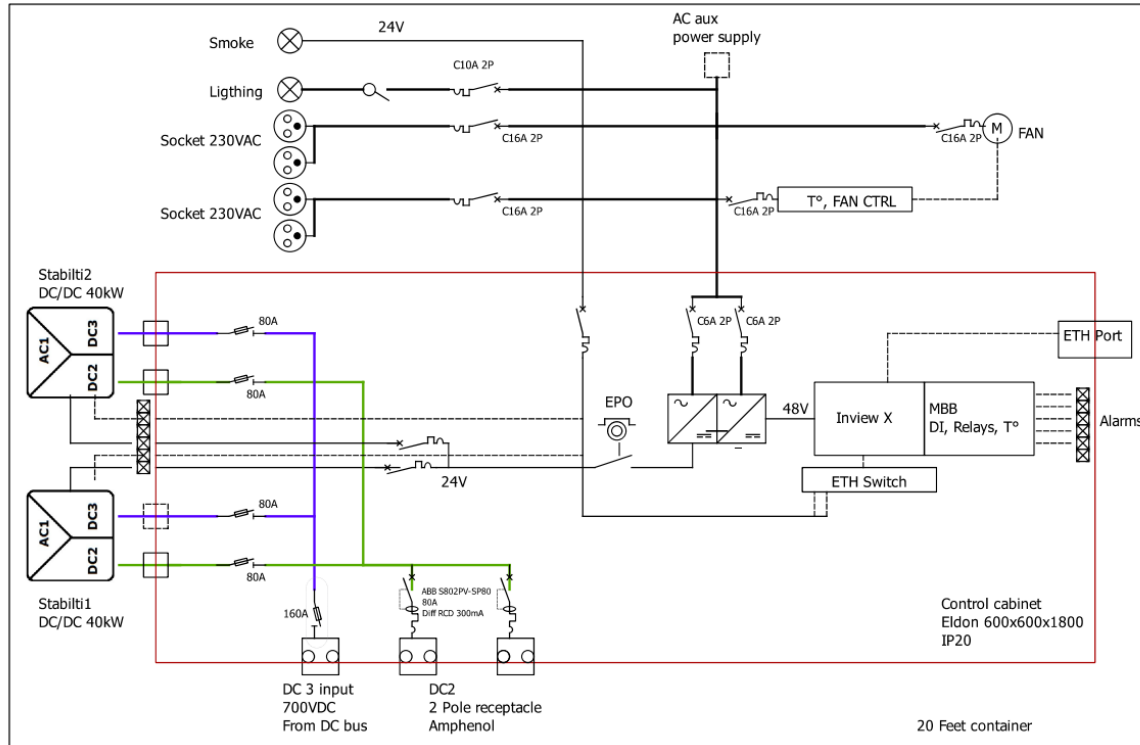

2 Stabiliti

20ft container

Inview X control cabinet

Amphenol Connector

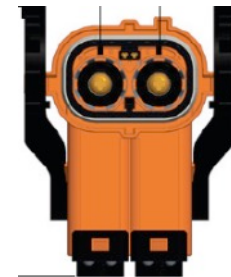

Criteria:

Price Technical Circularity Safety Performance

Why CE+T?

Proven DC microgrid solution

Real value add proposals

Flexibility of the solution

Lowest # conversions

2nd life EV car battery storage solution with swap warranty

Turnkey capabilities

Full service package

Thank you
for your attention

Check our website

www.cet-power.com

Follow us

